

SCALENET SOFTWARE INCLUDED



Program the LSQ according to your needs!

The LSQ-40L can be set up in two different ways:

Direct Programming

Option to enter 72 most used items through the programming keypad, just entering product name followed by the price and the assigned key acces. For more information please read the easy programming instructions described inside this brochure.

OR

Key programming/Software programming*

The LSQ 40L can also be programmed through the acces key (direct to the scale) or SCALENET software (from PC). SCALENET and key programming manuals are included on the cd.

OPTION TO PRINT DIFFERENT PAPER FORMATS

CUSTOM HEADING		
WEIGHT	PRICE \$	TOTAL \$
T-BONE		
0.610lb	\$ 2.08	1.27
SIRLOIN		
0.735lb	\$ 1.59	1.17
		2.44
CASH	\$	10.00
CHANGE	\$	7.56

2001002058752
THANK YOU AND COME AGAIN

Continuous paper 2.2" / 56 mm with or without adhesive

MY SHOP		
FRUIT CAKE		
FLOUR, EGG, SUGAR, BUTTER, BAKING POWDER, MILK, WHIPPED CREAM & FRUITS		
PACKED ON	SALE BY	
17/04/99	27/04/99	
NET WEIGHT	PRICE SLB	TOTAL \$
2 lbs	\$ 2.00	\$ 4.00

2123456010953
KEEP REFRIGERATED

48 x 38 mm / 1.8" x 1.49" Label

MY SHOP		
FRUIT CAKE		
FLOUR, EGG, SUGAR, BUTTER, BAKING POWDER, MILK, WHIPPED CREAM & FRUITS		
PACKED ON	SALE BY	
17/04/99	27/04/99	
NET WEIGHT	PRICE SLB	TOTAL \$
2 lbs	\$ 2.00	\$ 4.00

2123456010953
KEEP REFRIGERATED

56 x 40 mm / 2.2" x 1.57" Label

The following programmable features are available:

- 300 - 10,000 PLU's memories.
- Printing formats and personalizad formats.
- Label's Headlines
- Option to enter ingredients
- Scrolling promotion messages
- Configure cash register functions, returns, discounts and non weighed products.
- Programming Bar code.
- 72 direct access memory keys through the keypad included.
- Up to 20 programmed sellers
- Printable lists and sales reports
- Etc

*Custom programming has to be done to meet customer needs and can be done by the customer or by the dealer. Custom programming is not included in the product price.

DIMENSIONS

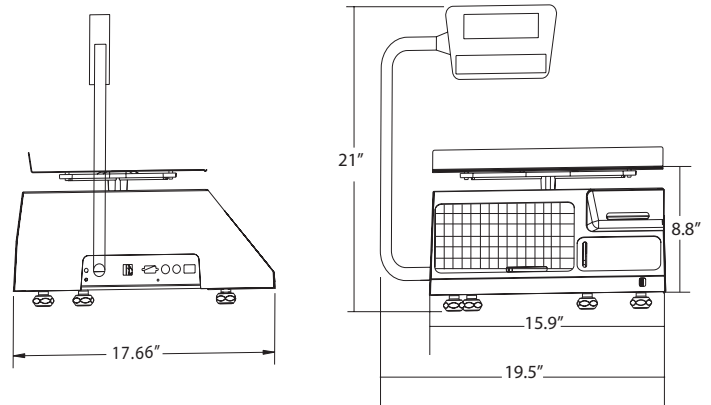

Two standard formats, option to personalized choosing continuous paper or label, setting the desire information on it, including bar code.

LSQ	
Capacity	20 kg / 40 lbs
Minimum division	0.005 kg / .01 lb
Weighed minimal unit	100 g / .02lb
Programmable memories	300 (Up to 10,000 memories optional)
Backlight	Included
Power Input	110 v/60 Hz (220 v/ 50 Hz Optional)
Adaptor	Included
Plate	15 X 12 " (38 x 30 cm)
Maximum tare	10 kg/20lb
Price lb/max	999.99 (99.999 optional)
Price \$/max	9999.99 (999.999 optional)
Range of operation temp	- 10 a 40° C (14 a 104 °F)
Renge of Storage temp	- 20 a 50°C (-4 a 122°F)
Net weight	33.51 lb/ 15.2 kg
Shipping weight	43.21 lb/ 19.6 kg



EXPANSION MEMORY BOARD TO 10,000 PLU's

With the expansion memory board you can up the PLU from 300 to 10,000 PLU's. (optional accessory, not included)



NTEP CC No. 00-135A1
*Available only in equipment ordered under This spec

